

# Market

The Original



**smeva**  
part of the smeva refrigeration group



Open character, spacious feeling





## Your own fresh market

The original Market, introduced by Smeva in 2005, is a self-service display case in which pre-packaged refrigerated products are presented with the appearance of a market square was introduced in 2005. The Market is a very spacious display case that cools perfectly with its sloping, deep presentation plateau.

With its open design, the products can be seen at a glance and lie at a convenient height. The many design options allow you to customize the Market to meet your needs.

Segmented bumpers and additional frames create the impression of small, individual display cases, which reinforces the marketplace feeling. If desired, however, the Smeva Market can be delivered as a single 3.75 metre-long element.

All the pre-packaged products, such as meat, fish, vegetables, cheese, tapas and meals, can be refrigerated in the Market.





# Configuration

Various configurations are possible with the Market.

- ▶ Stand alone
- ▶ Back-to-back
- ▶ Island with head unit

The Market is available in a plug-in version, which is easy to move and therefore perfectly suitable as a promo display case. Or in a remote version, where a compressor unit is required.



*Stand alone*



*Back-to-back*



*Island with head unit*











# Product temperature guaranteed

## Refrigeration performance

- ▶ Perfect temperatures
- ▶ 3M2 classification



## We have our own high-end test lab

- ▶ Testing in accordance with international standards
- ▶ ISO 23953 standard
- ▶ Simulation of all desired conditions: temperature, humidity, air speed and light intensity

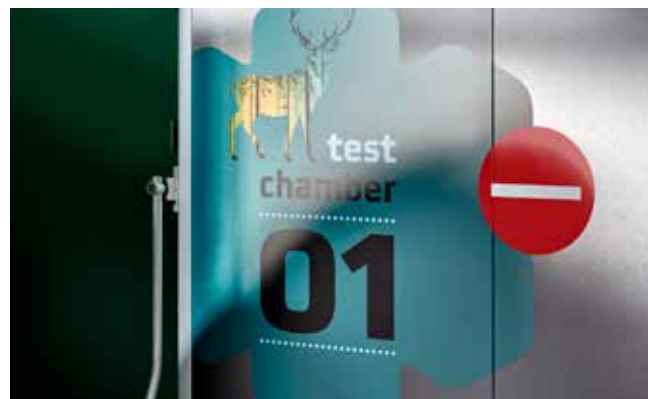



Design to your own wishes





# Design options

## 1. Internals

- ▶ Stainless steel
- ▶ Painted

## 2. Shelf type

- ▶ Glass
- ▶ Metal
- ▶ Wire shelves

## 3. Supports

- ▶ RAL painted
- ▶ Stainless steel

## 4. Frame

- ▶ Curved legs
- ▶ Straight legs
- ▶ Diagonal legs
- ▶ Closed legs

## 5. Ends

- ▶ Stainless steel
- ▶ RAL colour

## 6. Bumper rail

- ▶ Stainless steel
- ▶ Boston rubber

## 7. Lighting

- ▶ LED



*Interior*



*Glass shelves*

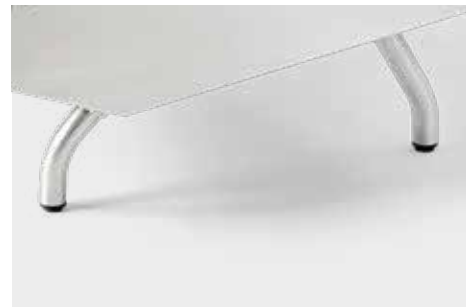

*Frame with curved legs*

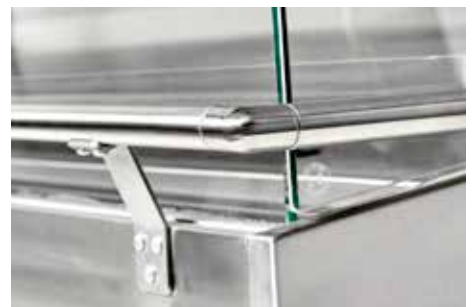

*Stainless steel bumper rail*



*LED lighting*

# Versions

## Slim Line (SL)

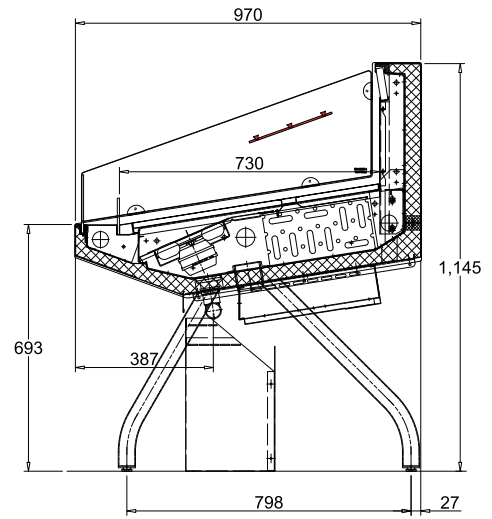

Slim Line

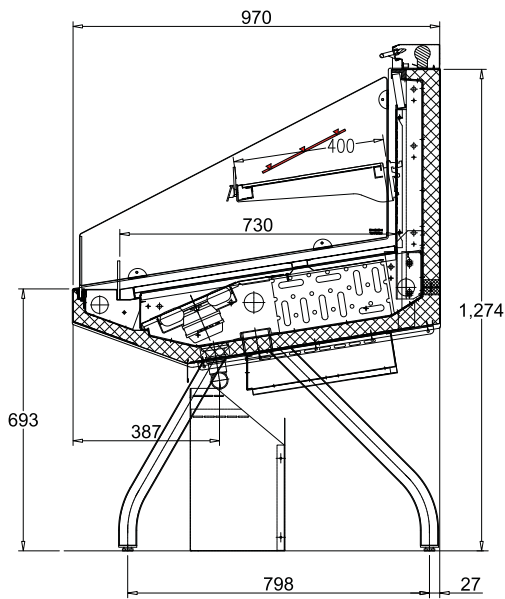

Slim Line 1 shelf

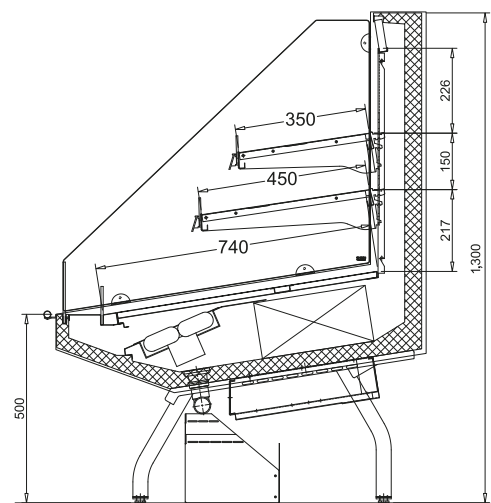

Slim Line 2 shelves

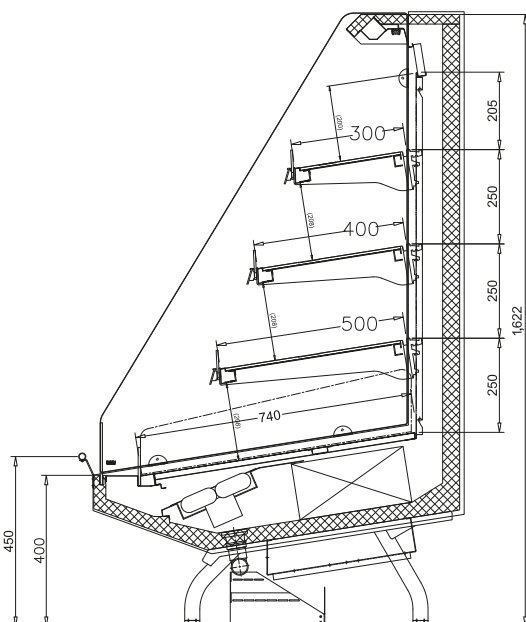

Slim Line 3 shelves

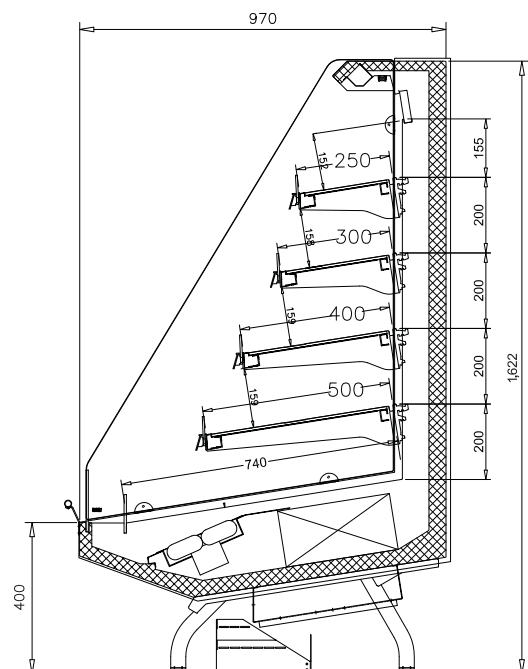

Slime Line 4 shelves



# Versions

## Regular Line (RL)

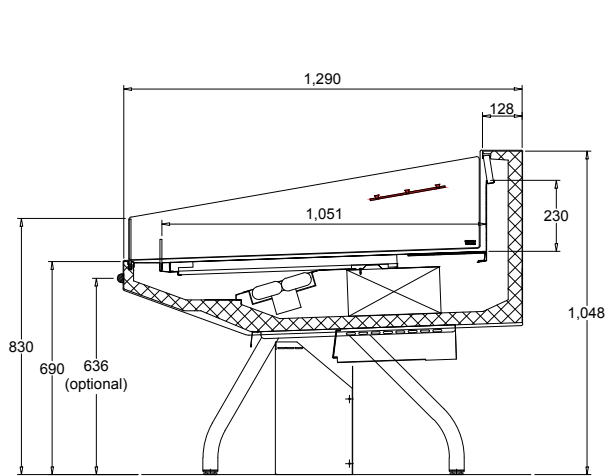

Regular Line with 2° angle

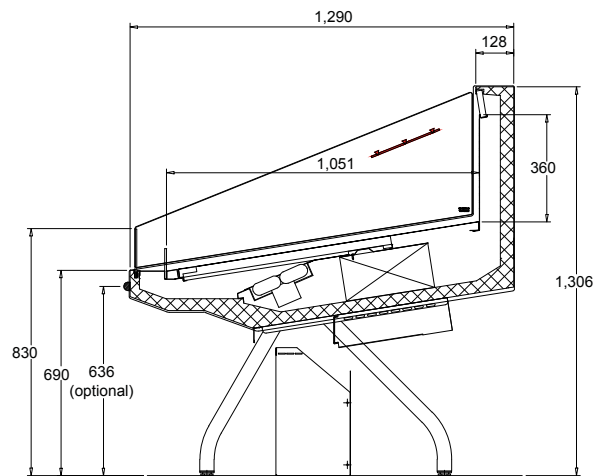

Regular Line with 9° angle

# Modular construction

Market display cases are modularly constructed, with sections ranging in length from 1,250 mm to 3,750 mm. The Market is infinitely extendable, in increments of 625 mm. This allows you to assemble a display case of any desired length.

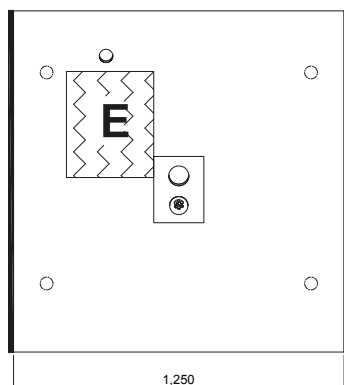

Consumer

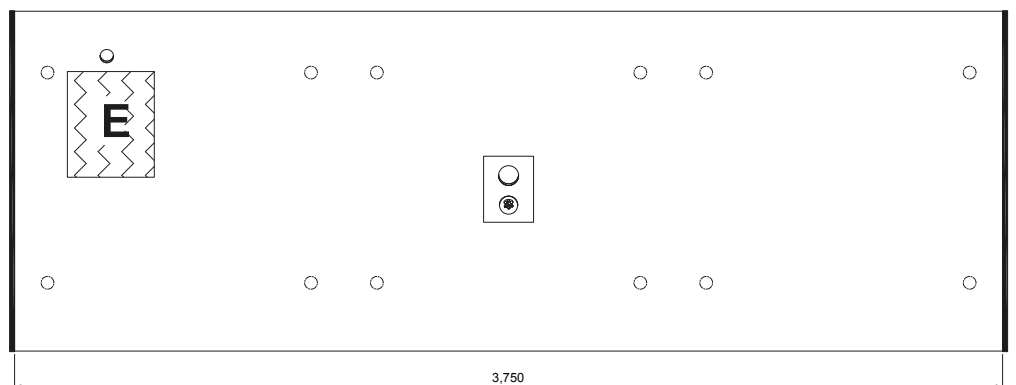

Consumer

# Market Plug-in

## Applications

### Propane R433A natural refrigerant

- ▶ Ultra low GWP < 3
- ▶ Strong distinctive odour (for safety)
- ▶ Very high energy efficiency compared to HFC/HCFC



*Market Plug-in - R433A propane*



*Market Plug-in - R433A propane with shelves*

Perfectly suited for flexible presentation  
of promotional products



## Versions

- ▶ Angle of inclination 2° / 9°
- ▶ Lengths 1,250 mm and 1,875 mm
- ▶ Max. height back 1,500 mm
- ▶ Min. height front 600 mm



# Let yourself be inspired

Visit our showroom and factory, where you will experience the products and see our specialists doing what they love. Or accompany us to inspiring locations furnished with Smeva refrigerated retail display appliances.





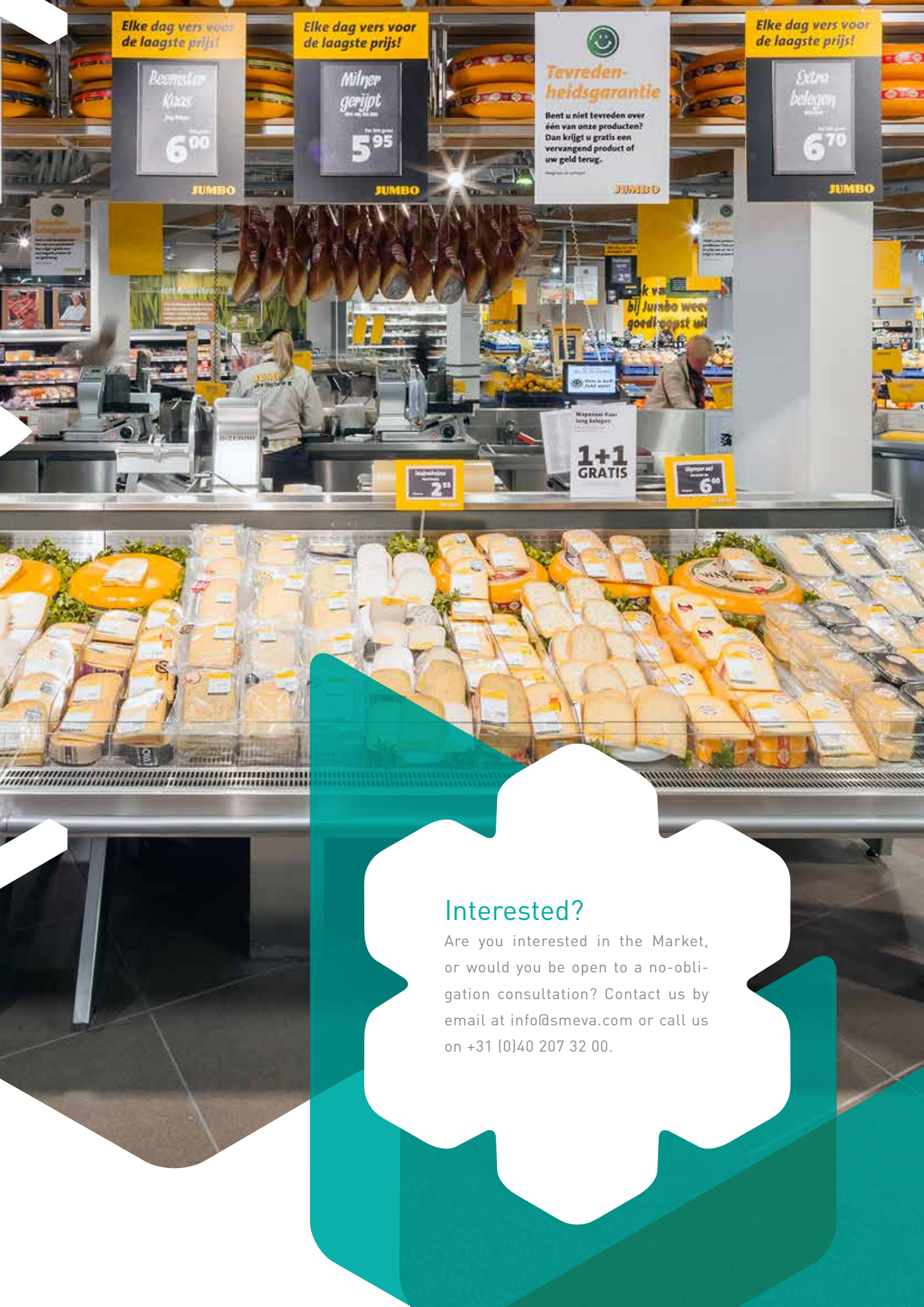

Elke dag vers voor de laagste prijs!

Beemster  
Kaas  
Per 100 gram  
**6<sup>00</sup>**

JUMBO

Elke dag vers voor de laagste prijs!

Milner  
gerijpt  
Per 100 gram  
**5<sup>95</sup>**

JUMBO



Tevreden-  
heidsgarantie

Bent u niet tevreden over één van onze producten? Dan krijgt u gratis een vervangend product of uw geld terug.

JUMBO

Elke dag vers voor de laagste prijs!

Extra  
beleggen  
Per 100 gram  
**6<sup>70</sup>**

JUMBO

1+1  
GRATIS

## Interested?

Are you interested in the Market, or would you be open to a no-obligation consultation? Contact us by email at [info@smeva.com](mailto:info@smeva.com) or call us on +31 (0)40 207 32 00.



**smeva**  
part of the smeva refrigeration group

**Smeva B.V.**

J.F. Kennedylaan 27  
5555 XC Valkenswaard  
Postbus 30  
5550 AA Valkenswaard  
The Netherlands  
T +31 (0)40 207 32 00  
info@smeva.com  
[www.smeva.com](http://www.smeva.com)

We are enthusiastic about cooling. This is what distinguishes Smeva from the competition. We've been developing, manufacturing and supplying first-class refrigeration and freezer solutions for customers across the world since 1920. Smeva supplies to specialty stores, supermarkets, healthcare and non-profit organisations, hotels, restaurants and caterers, and to the non-food industry. Optimal storage conditions and high-quality guaranteed everywhere.

**Dedicated to freshness**  
Since 1920